

TECHLITE® SILENCER PIPE + DUCT LAGGING INSTALLATION INSTRUCTIONS



Installation procedures for Pipe and Duct Lagging accessories may vary from manufacturer to manufacturer. For specific accessory component information, detail drawings, CAD design assistance, detailed information or other technical services, please contact Techlite Acoustics engineering and sales team for guidance. Note: If significant changes to structure are to be made due to the weight of the pipe and duct lagging, such installation impacts appropriately land in the purview of a structural engineer or general contractor licensed in the state where installation occurs.

The following information is intended to serve as general guidelines for installing Techlite Acoustics Pipe and Duct Lagging.

Materials

1. Melamine Foam Decoupler – Minimum ¼” thick melamine foam decoupler with density of ½ pound per cubic foot. For fire rated installations and for high temperature mechanical applications, make sure the lagging material meets all applicable building codes and material standards.
2. Techlite Pipe and Duct Lagging – The lagging material is 1pound per square foot mass loaded vinyl. For specific technical information, lab data, specifications, refer to the product data sheet. 1/3 Octave band STC (dB) data available upon request.
3. Metal or Nylon Straps/Banding, Foil Lag Tape, Mylar Scrim Tape, Spray Contact Adhesive

Installation Instructions

- A. Before installing Techlite’s Pipe and Duct Lagging, it would be wise to review all applicable building construction codes to ensure lagging materials installed are in line with the standards suitable for building construction.
- B. The outer surface of the pipe or duct should be clean, free of dirt, dust, etc.

- C. Measure the circumference of the pipe and/or circular duct and add 2-4" of additional material, to allow the material to overlap
- D. Standard lagging products include 2'x4'x3/8", 4'x8'x3/8", and 48"x30'x3/8" roll and comes with a light grey melamine foam decoupler adhered to black mass loaded vinyl. If installing the lagging using the 48"x30' roll, with a utility knife (or equivalent) field cut and apply the melamine foam decoupler to the face of the mass loaded vinyl. Wait approximately 5 minutes for adhesive to fully dry.
- E. Install first section of the lagging and wrap the lagging material around the pipe or duct. Coverage of the pipe insulation being treated must be continuous. Roll out the product to an appropriate length and measure the coverage required to fit around the pipe/duct. Allow for an overlap of the lagging material by a minimum of 2" up to 4" and adhere the lagging material.
- F. Drape the cut piece over the pipe or duct with equal parts of the product hanging over each side of the pipe or duct. One side of the lagging material is brought up and adhered to the pipe or duct with a foil lag or Mylar scrim tape. The other side is then brought up, taping the overlapping joint, sealed and secured with tape to the pipe or duct. This method allows for a single seam running along the bottom of the pipe or duct. Wipe or rub the tape with firm pressure across the tape with a cloth or equivalent to smooth out any air bubbles or buckles. Note: For hot pipe applications, all joints to be held in place with metal banding to ensure any residual moisture in the pipeline system can escape. Do not solely use tape for hot pipe applications.
- F. For an additional level of security, we advise metal or nylon banding be wrapped around the outside of the lagging material in addition to the tape. If used, this banding should be placed on either side of all seams in addition to the midpoint on longer sections. Ensure that the banding is snug only and does not result in compression of the decoupler material beneath the lagging. In lieu of banding, "stick pins" can be used to reinforce the seams in the lagging material. These pins typically are impaled through the mass loaded vinyl and decoupler, and are then fuse-welded to the pipe or duct beneath. As before, ensure that the pin does not compress the decoupler to the point of deterioration.

Figure 1: MLV Overlap Method for Ductwork

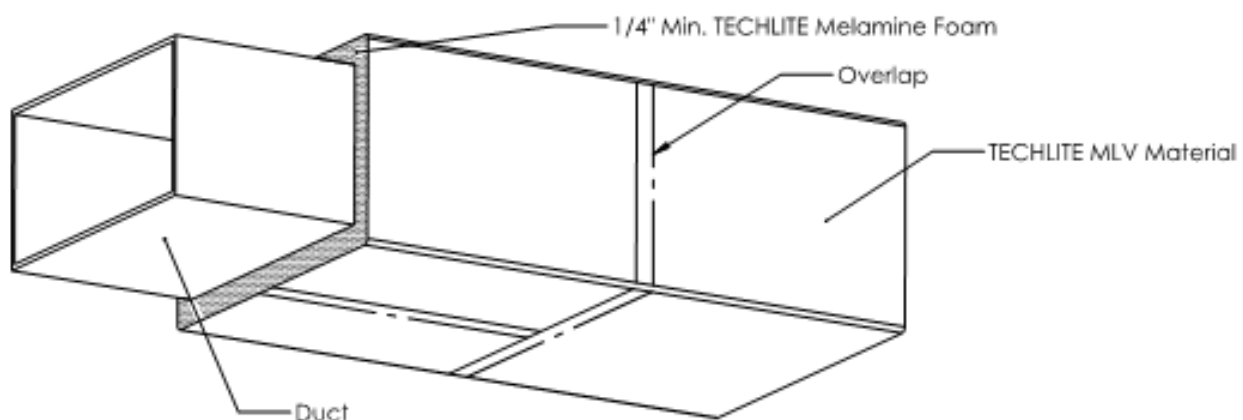
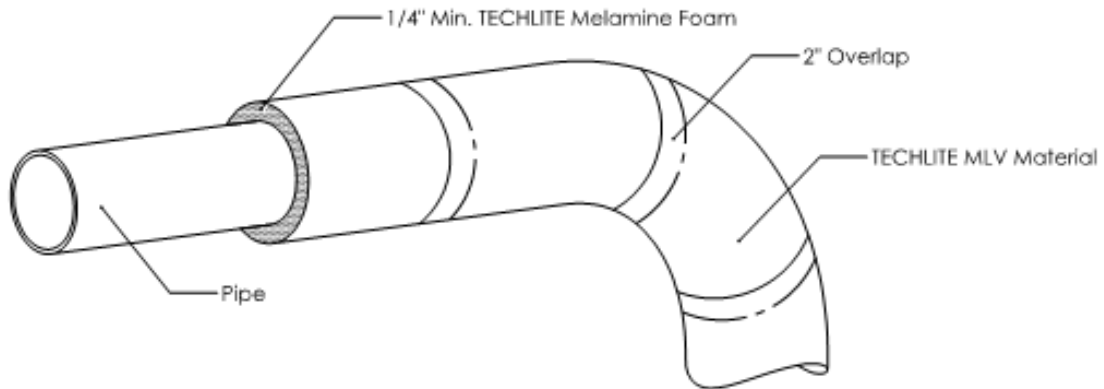

Figure 2: MLV Overlap Method for Pipe



Please consult TECHLITE Acoustics Engineering Department for technical assistance to suit your specific project requirements.